

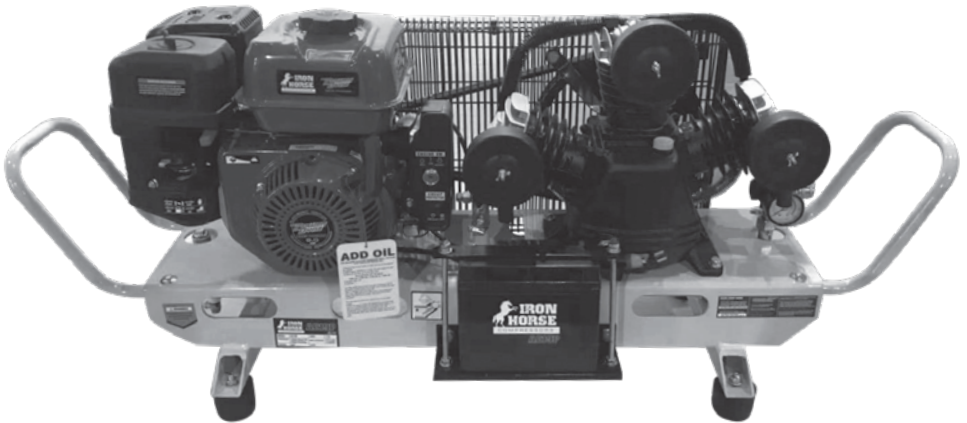

IRON HORSE

COMPRESSORS

AC19P AIR COMPRESSOR



INSTRUCTION MANUAL

CONTENTS

Cautions.....	3
Environmental Protection.....	3
Description of Symbols.....	3
Meanings of Signal Words.....	3
Safety	4
Specifications.....	6
Parts and Features.....	7
Replacement Parts.....	7
Assembling the Compressor.....	8
Quick Start Guide.....	9
Maintenance.....	10
Oil Changes and Topping Up.....	11
Troubleshooting.....	12
Hints for Efficient Operation.....	13
Storing the Compressor.....	13
Pneumatic Connections.....	13
Notes.....	14
Warranty.....	15

Dear Customer,

If you require any help with your product, whether it is a warranty claim, spare part or user information, please visit www.euroquip.co.nz first and register your product online. Once registered, please log a request online or call us on 0800 387 678

Your new Iron Horse Compressor should more than satisfy your expectations. It has been manufactured under stringent AS/NZS Quality Standards to meet superior performance criteria.

CAUTIONS

Read and understand all of the operating instructions, safety precautions and warnings in the Instruction book before operating or maintaining this compressor.

Most accidents that result from compressor operation and maintenance are caused by the failure to observe basic safety rules or precautions. An accident can often be avoided by recognizing a potential hazardous situation before it occurs, and by observing appropriate safety procedures.

Basic safety precautions are outlined in the "SAFETY" section of this Instruction Manual and in the sections which contain the operation and maintenance instructions.

Hazards that must be avoided to prevent bodily injury or machine damage are identified by WARNINGS on the compressor and in this Instruction Manual.

Never use this compressor in a manner that has not been specifically recommended by manufacturer, unless you first confirm that the planned use will be safe for you and others.

ENVIRONMENT PROTECTION



Recycle unwanted materials instead of disposing of them as waste. All tools, hoses and packaging should be sorted, taken to the local recycling centre and disposed of in an environmentally safe way.

DESCRIPTION OF SYMBOLS

The rating plate on your tool may show symbols. These represent important information about the product or instruction on it's use.



Wear hearing protection
Wear eye protection
Wear breathing protection



Conforms to relevant standards for electromagnetic compatibility.

MEANINGS OF SIGNAL WORDS

⚠ WARNING: Indicates a potential hazardous situations which, if ignored, could result in serious personal injury.

⚠ CAUTION: Indicates a hazardous situation which, if ignored, could result moderate personal injury or could cause machine damage.

NOTE: Emphasizes essential information.

SAFETY

IMPORTANT SAFETY INSTRUCTIONS FOR USE OF THE COMPRESSOR

⚠ WARNING: Death or serious bodily injury could result from improper or unsafe use of compressor. To avoid these risks, follow these basic safety instructions.

READ ALL INSTRUCTIONS

1. Never touch moving parts

Never place your hands, fingers or other body parts near the compressor's moving parts.

2. Never operate without all guards in place

Never operate this compressor without all guards or safety features in place and in proper working order. If maintenance or servicing requires the removal of a guard or safety features. Be sure to replace the guards or safety feature before resuming operation of the compressor.

3. Always wear eye protection

Always wear safety goggles or equivalent eye protection. Compressed air must never be aimed at anyone or any part of the body.

4. Protect yourself against electric shock

Prevent body contact with grounded surfaces such as pipes, radiators, ranges and refrigeration enclosures. Never operate the compressor in damp or wet locations.

5. Disconnect the compressor

Always disconnect the compressor from the power source and remove the compressed air from the air tank before inspecting, maintaining, cleaning, replacing or checking any parts.

6. Avoid unintentional starting

Do not carry the compressor while it is connected to its power source or when the air tank is filled with compressed air. Be sure the knob of the pressure switch in the "OFF" position before connecting the compressor to its power source.

7. Store compressor properly

When not in use, the compressor should be stored in dry place. Keep out of reach of children. Lock-out the storage area.

8. Keep work area clean

Cluttered areas invite injury. Clear all work areas of unnecessary tools, debris, furniture etc.

9. Keep children away

Do not let visitors contact compressor extension cord. All visitors should be kept safely away from work area.

10. Dress properly

Do not wear loose clothing or jewelry. They can be caught in moving parts. Wear protective hair covering to contain long hair.

11. Don't abuse the cord

Never yank it to disconnect from receptacle. Keep cord from heated oil and sharp edges.

12. Maintain compressor with care

Follow instructions for lubricating. Inspect cords periodically and if damaged, have repaired by authorized service facility. Inspect extension cords periodically and replace if damaged.

13. Outdoor use extension cords

When compressor is used outdoors, use only extension cords intended for use outdoors and so marked.

14. Stay alert

Watch what you are doing. Use common sense.

Do not operate compressor when you are tired. Compressor should never be used if you are under the influence of alcohol, drugs or medication that makes you drowsy.

15. Check damaged parts and air leak

Before further use of the compressor, a guard or other part should be carefully checked to determine that it will operate properly and perform its intended function. Check for alignment of moving parts, binding of moving parts, breakage of parts, mounting, air leak, and any other conditions that may affect its operation. A guard or other part that is damaged should be properly repaired or replaced by an authorized service centre unless otherwise indicated elsewhere in this Instruction Manual. Have defective pressure switches replaced by authorized service centre. Do not use compressor if switch does not turn it on and off.

16. Handle compressor correctly

Operate the compressor according to the instructions provided herein. Never allow the compressor to be operated by children, individuals unfamiliar with its operation or unauthorized personnel.

17. Keep all screws, bolts and covers tightly in place

Keep all screws, bolts, and plates tightly mounted. Check their conditions periodically.

18. Keep motor air vent clean

The motor air vent must be kept clean so that air can freely flow at all times. Check for dust build-up frequently.

19. Operate compressor at the rated voltage

Operate the compressor at voltages specified on their nameplates. If using the compressor at a higher voltage than the rated voltage, it will result in abnormally fast motor revolution and may damage the unit and burn out the motor.

20. Never use a compressor which is defective or operating abnormally

If the compressor appears to be operating unusually, making strange noises, or otherwise appears defective, stop using it immediately and arrange for repairs by an authorized service centre.

21. Do not wipe plastic parts with solvent

Solvents such as gasoline, thinner, benzene, carbon tetrachloride, and alcohol may damage and crack plastic parts. Do not wipe them with such solvents. Wipe plastic parts with a soft cloth lightly dampened with soapy water and dry thoroughly.

22. Use only genuine replacement parts

Replacement parts not original may void your warranty and can lead to malfunction and resulting injuries. Genuine parts are available from your dealer.

23. Do not modify the compressor

Do not modify the compressor. Always contact the authorized service centre any repairs. Unauthorized modification may not only impair the compressor performance, but also may result in accident or injury to repair personnel who do not have the required knowledge and technical expertise to perform the repair operations correctly.

24. Turn off the pressure switch when the compressor is not used

When the compressor is not used, turn the knob of the pressure switch OFF, disconnect it from the power source and open the drain cock to discharge the compressed air from the air tank.

25. Never touch hot surface

To reduce the risk of burns, do not touch tubes, heads, cylinder and motors.

26. Do not direct air stream at body

Risk of injury, do not direct air stream at persons or animals.

27. Drain tank

Drain tank daily or after 4 hours of use. Open drain fitting and tilt compressor to empty accumulated water.

SPECIFICATIONS

Pump Type:	'V' 3 Cylinder Cast Iron Single Stage
Engine:	Powerdyne 8HP, 4 Stroke, Petrol, 233CC Electric Start
Receiver Size:	3.5L
FAD:	300 L/min
Pump Displacement:	477L/min (16.8cfm)
FAD @ Working Pressure:	270L/min
Working Pressure:	7 - 9 Bar, 100 - 130 psi
Max. Pressure:	9 Bar
Pump Speed:	830 rpm
Pump Unloader System:	Integrated Non-Return External Vent Unloader
Fuel Tank Capacity:	3.6L
Sound Pressure Level:	80dBA
Warranty:	Commercial 12 Months
Dimensions:	950 x 350 x 520mm (LxWxH)
Weight (Gross):	70kg

PARTS & FEATURES

1. Safety Valve
2. Pump Air Filters
3. Pump Oil Filler Cap
4. Pump Sight Glass (Oil Level)
5. Tank Drain Valve
6. Recoil Starter
7. Engine Oil Filter / Dipstick
8. Compressor Pump
9. Tank Gauge
10. Air Tank
11. Unloader / Non-Return Valve
12. Air Filter
13. Electric Start Battery
14. Air Outlet Manifold

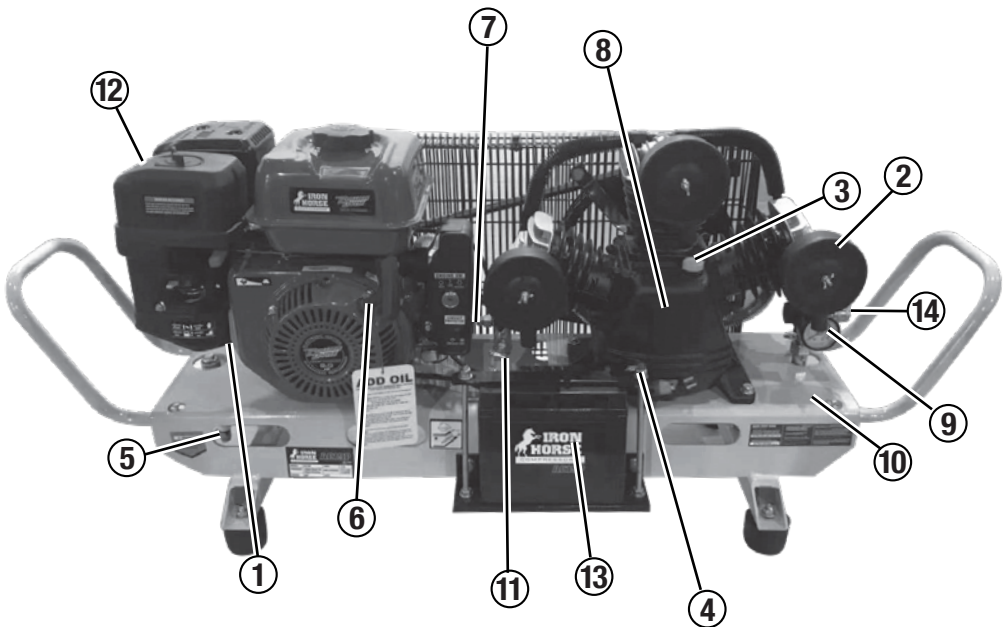

REPLACEMENT PARTS

When servicing use only identical replacement parts. Repairs should be conducted only by authorized service centre.

ASSEMBLING THE COMPRESSOR

NOTE: The information contained in this Instruction Manual is designed to assist you in the safe operation and maintenance of the compressor. Some illustrations in this Instruction Manual may show details or attachments that differ from those on your own compressor.

1. Remove the compressor from its packing (Fig.1). Make sure it is in perfect condition, check if it was damaged during transport, and carry out the following operations.
 2. Fit the wheels and rubber tab on the tanks on which they are not already fitted, observing the instructions (Fig.2). In case of inflatable wheels, the maximum inflation pressure must be of 1.6 bar (24psi).
 3. Position the compressor on a flat surface or with a maximum permissible inclination of 10° (Fig. 3), in a well aired place, protected
- against atmospheric agents and not in a place subject to explosion hazard.
4. To ensure good ventilation and efficient cooling, the compressor's belt guard must be at least 1 metre from any wall (Fig. 4). Compressors fitted on the tank, with fixed feet, should not be rigidly secured to the ground. In this case, we advise you to fit 4 anti-vibration supports.
 5. Take care to transport the compressor correctly, do not overturn it or lift it with hooks or ropes (Fig. 5)
 6. Replace the plastic plug on the guard cover (Fig. 7-8) with the oil level stick (Fig. 9) or with the relevant breather plug (Fig. 10), supplied with the instructions booklet.

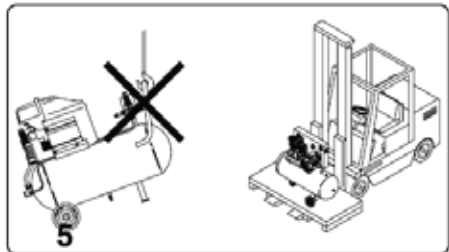
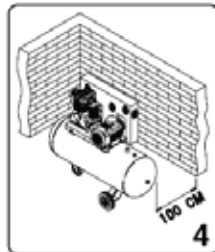
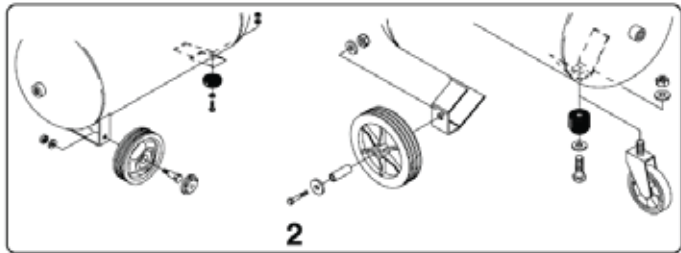



7. Check oil level, consulting the reference marks on the stick (Fig. 9) or the oil level inspection window (Fig. 11).

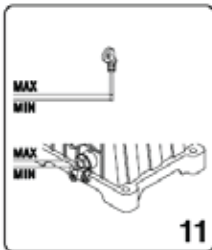
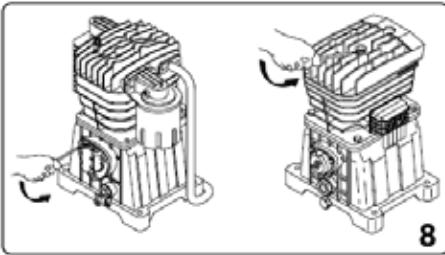

QUICK START GUIDE

1. Add Engine Oil:

- Ensure engine is kept perfectly upright / level.
- Fill until oil runs back out of filler hole

DO NOT OVERFILL

DO NOT TILT WHILE FILLING

OIL TYPES: 10W30 / 10W40 / 15W30 / 15W40

2. Compressor Oil Level:

- Check that compressor unit oil level is correct

OIL TYPE: HYDRAULIC ISO VG 100

3. Connect Battery (if equipped):

- Connect red to red (+)
- Connect black to black (-)

NEVER REVERSE BATTERY CONNECTIONS OR PERMANENT NON-WARRANTABLE DAMAGE WILL OCCUR.

4. Add Fuel:

- Use only clean, fresh commercially available fuel.

5. De-pressurise Air Tank:

- Tank pressure must be low to allow starting
- If starting with any pressure in air tank, activate manual over-ride toggle on the unloader valve first.

6. Turn the Fuel Valve to "ON"

7. Switch the Engine Switch to "ON"

8. Set the Choke:

COLD ENGINE - Move the choke lever to left

WARM ENGINE - Move the choke lever to right.

9. Start the Engine:

KEY START (If equipped) - Turn the ignition key "ON". If the battery has enough charge, use the ignition key to start the engine by holding the key in the "START" position for a few seconds (new batteries have little or no charge. Use pull start, jump start or charge battery if needed).

PULL START - Pull cord repeatedly until the engine starts.

9. Move the choke lever to the right

IF ENGINE WILL NOT START:

- Repeat the process above but place and leave the choke lever to the right.
- Check oil level
- Charge battery or jump start
- Repeat process above
- Ensure there is no air pressure left in the tank

MAINTENANCE

Before attempting any maintenance jobs on the compressor, make sure there is no pressure on the air tank:

Every 50 Hrs of Duty:

We advise you to dismantle the suction filter and clean the filtering element by blowing compressed air on it (Fig. 12).

You are recommended to replace the filter element at least once if the compressor operates in a clean environment, but more frequently if in a dusty environment.

The compressor generates condensate water which accumulates in the tank. The condensate in the tank must be drained at least once a week, by opening the drain tap (Fig. 13) under the tank. When draining, take care if there is compressed air inside the cylinder as water could flow out with considerable force.

Recommended Pressure:

1 - 2 bar. Condensate of compressors that are oil lubricated must not be drained into the sewer or dispersed in the environment as it contains oil.

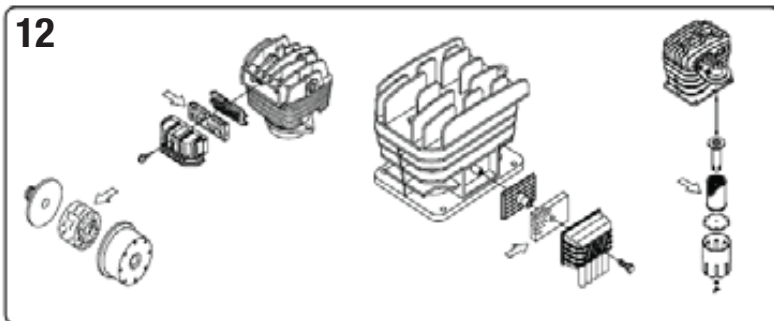

OIL CHANGES & TOPPING UP

We recommend a full change of oil in the pump within the first 100 hours of duty.

OIL TYPE: HYDRAULIC ISO VG 100 Grade or equivalent

1. To change the oil, unscrew the oil drain plug on the housing cover.
2. Allow all the oil to flow out, and re-screw the plug (Fig. 14 - 15).

3. Pour oil into the upper hole of the housing cover (Fig. 16 - 17) until it reaches the level indicated on the stick (Fig. 9) or indicator (Fig. 11) Pour oil into the upper hole of the head (Fig. 17) in belt assisted units designed for topping up in that area.

Once a Week:

Check oil level of the pumping element (fig. 11) and see if it needs topping up.

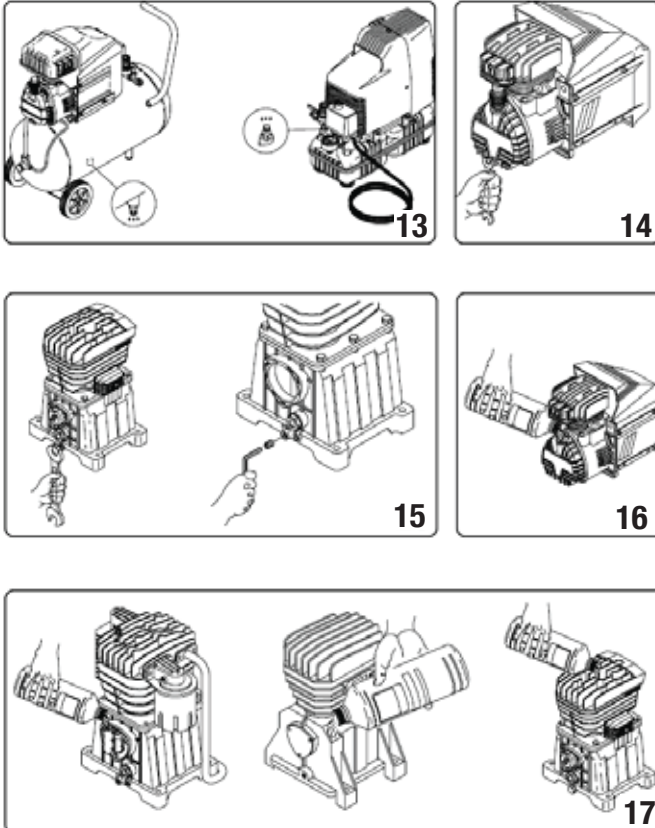

TROUBLESHOOTING

Loss of air in unloader valve.

This trouble depends on poor tightness of the check valve – take the following action (Fig. 18):

1. Discharge all pressure from the tank
2. Unscrew the hexagon-head of the valve (A)
3. Carefully clean both the rubber disk (B) and its seat.
4. Refit all parts accurately.

Air losses

These can be caused by poor tightness of a union – check all unions, wetting them with soapy water.

Compressor turns but does not load

Coaxial compressors: (Fig. 19)

This may be due to failure of the valves (C1 – C2) or of a seal (B1 –B2). Replace the damaged part.

Pulley drive compressors: (Fig. 20)

This may be due to failure of the valves F1 and F2 or of D2). Check if there is too much condensate water inside the tank or replace the damaged part.

IMPORTANT:

- Do not on any account unscrew any connection while the tank is pressurized - always check if the tank is pressure free.
- Do not drill holes, weld or purposely deform the compressed air tank.
- Do not do any jobs on the compressor unless you have disconnected the power plug.
- Temperature in operating ambient: 0°C +35°C.
- Do not aim jets of water or inflammable liquids on the compressor.
- Do not place inflammable objects near the compressor.
- During down-times, turn the pressure switch to position “0” (OFF).
- Never aim the air jet at people or animals (Fig. 21)
- Do not transport the compressor while the tank is pressed. Be careful with regard to some parts of the compressor such as the head and delivery tubes, as they can reach high temperatures. Do not touch these parts to avoid burns.

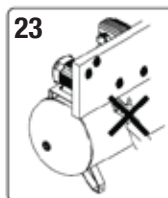
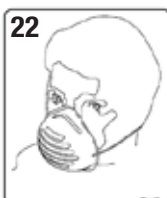
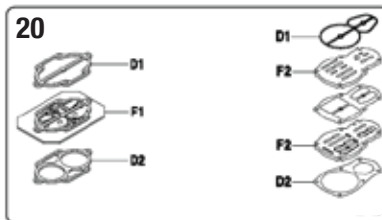
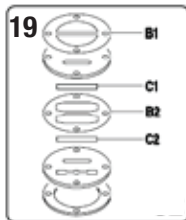
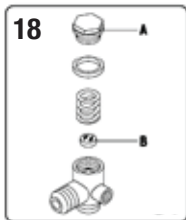

- Transport the compressor, lifting or pulling it with the appropriate handles (Fig. 4 - 6)
- Keep children and animals well away from the machine operating area.
- If using the compressor for painting:
 - a) Do not work in closed environments or near to naked flames
 - b) Make sure there is adequate exchange of air at the place of work
 - c) Protect your nose and mouth with an appropriate mask. (Fig. 22)
- If the electrical cable or plug is damaged, do not use the compressor and contact an authorised service centre to replace the faulty element with an original spare part.
- If the compressor is located on a shelf or on a top above floor height, it must be secured to prevent it falling while in operation.
- Do not put objects or your hands inside the protective grilles to avoid injury to yourself or damaging the compressor. (Fig. 23)
- Do not use the compressor as a blunt object toward things or animals, to avoid serious damage.
- When you have finished using the compressor, always remove the plug from the power socket.

Acoustic pressure measured free-field at a distance of 1m: 80dB(A) at maximum operating pressure.

HINTS FOR EFFICIENT OPERATION

For efficient operation of the machine at full continuing load and at maximum operating pressure, make sure the temperature of the work environment does not exceed +25°C. We advise you to use the compressor at 70% maximum duty per hour at full load as this ensures efficient operation of the product long-term.

STORING THE COMPRESSOR

For the whole time that the compressor is not used before unpacking it, store it in a dry place at a temperature between +5°C and + 45°C and sheltered away from weather.

For the whole time that the compressor is not used after unpacking it, while waiting to start it up or due to production stoppages, place sheets over it to protect it from dust, which may settle on the components. The oil is to be replaced and the operational efficiency of the compressor is to be checked if it is not used for long periods.

PNEUMATIC CONNECTIONS

Make sure you always use pneumatic hoses for compressed air with maximum pressure characteristics that are adequate for the compressor. Do not attempt to repair tubes if faulty.

NOTES:

WARRANTY

As part of an on-going commitment to excellence in product support, Euroquip offers a comprehensive product warranty program.

In order to qualify for full warranty support, your product must be registered. If a Euroquip dealer has not already registered your product, please register it online at www.euroquip.co.nz.

Registered warranty period for the AC19P Compressor:

Commercial Use: 12 Months

Warranty covers failure caused by manufacturing and material defects in the product, during the warranty period specified. The warranty period begins when the product is purchased by the end user. Warranty is not transferrable and is only claimable by the original purchaser.

Warranty does not cover parts that are subject to wear and tear from usage.

Warranty covers failure of a product caused by defective materials and/or manufacturing for the period given and the usage specified by Euroquip. The warranty period begins when the product is purchased by the end user. Warranty is not transferrable and is only claimable by the original purchaser.

Warranty also does not cover failure caused by the untimely replacement or service of the above wearing parts. Evidence must be provided that the product has been maintained and serviced suitably for a claim to be considered under warranty.

Failure caused by incorrect operation of the product, lack of proper care and maintenance of the product, external damage, external circumstances such as contaminated fuel or poor water supply, modifications to the product, attempted repair/

service by a party other than an Approved Service Agent, is not covered under warranty.

Warranty does not cover pre delivery service and adjustment, or failure that may occur as a result of lack of/ incorrect pre delivery service and adjustment.

Warranty does not cover any incidental, indirect or consequential loss, damage or expense that may result from any defect, failure or malfunction of a product.

Should any issue be found to be a combination of a warranty failure and a non-warranty issue, the repair cost component to rectify and repair the non-warranty failure is the customers' full responsibility.

The decision that an issue with a product qualifies as a warranty claim is made at the sole jurisdiction of Euroquip.

No costs incurred will be considered under warranty if repairs are carried out by a party other than a Euroquip Approved Service Agent, unless with prior consent in writing from Euroquip.

It is the responsibility of the purchaser to deliver a product under warranty to the nearest relevant service agent or product reseller. Warranty does not cover call outs, mileage and freight costs.

If a product is repaired under warranty, parts and labour required for the repair will be supplied at no charge. Warranty assessment and repair will be scheduled and executed according to the normal work flow at the service location and depending on the availability of suitable replacement parts.

This warranty policy is an additional benefit and does not affect the legal rights of any end user, reseller or service agent.



Congratulations on your new Iron Horse Compressor purchase. We are proud to have you as our customer and will strive to provide you with the best service and reliability in the industry. This product is backed by our extensive warranty and service network. To locate your nearest distributor or service agency visit www.euroquip.co.nz or email us at customerservice@euroquip.co.nz.